

Connector Pin-out

Pin 1	I/O_01 selectable as Digital Input, Digital Output or Analog Input
Pin 2	RS232 Tx User Data (Output)
Pin 3	RS232 Rx User Data (Input)
Pin 4	Ground and Shield
Pin 5	Power Supply Voltage +9 to +32 VDC
Pin 6	I/O_02 same as I/O_01
Pin 7	I/O_03 same as I/O_01
Pin 8	I/O_04 selectable as Digital Input, Digital Output, Analog Input or Current Loop Input (4-20mA)

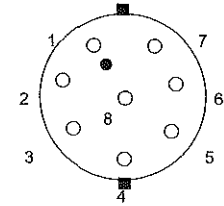

Rear view of mating connector (solder cups)

Mating Connector

Conxall #MINI-CON-X® 6282-8SG-3DC

LED Indicators

The Solution Provider can configure the terminal to disable all LEDs (except the startup sequence). The following outlines the LEDs state in the terminal's default operational mode.

STAT	This LED flashes to indicate the terminal's current operational state.
Tx	Indicates when the terminal is transmitting.
ERR	Indicates that the terminal detected an internal problem when on <u>continuously</u> . In this case, contact your Solution Provider for instructions.

Warranty Information

Warranty

SkyWave warrants its products and services will perform in accordance with SkyWave's specifications and will be free from defects in material and workmanship for a period of fifteen (15) months from date of shipment. This warranty is limited to the repair and/or replacement of any defective components experienced under normal specified operating use and storage conditions, at SkyWave's discretion. It does not cover any damages caused or associated with the product's misuse. Communicate experience with defective products to your Solution Provider. Ship any defective product, along with a fault report, back to the Solution Provider according to the Solution Provider's instructions. SkyWave is not responsible for corrosion damage caused by improperly assembled or installed cables. Warranty is void if unit is opened.

Limited Liability

SkyWave's liability is limited to the cost of repair or replacement of any of SkyWave's products during the warranty period. Consequential, indirect or similar damages associated with product application and usages are disavowed. SkyWave's products are not suitable for life critical applications. SkyWave's aggregate liability shall in no circumstances exceed the product's price as paid to SkyWave and this limitation of liability is reasonable given the price of SkyWave's products, which reflect reasonable allocation.

The DMR-800D is an Inmarsat IsatM2M mobile satellite communications terminal manufactured by SkyWave Mobile Communications Inc. SkyWave distributes the terminal through Solution Providers who activate the terminal on the SkyWave IsatM2M Network and provide application programs that communicate with the terminal.

This guide provides information required for a successful installation of the terminal on a vehicle, boat or other platform. This guide does not address the terminal's commissioning procedures as these procedures vary depending upon the Solution Provider and their specific application.

Configuration Options

The DMR-800D is available in a number of configurations with two standard mounting options.

Part Number	Configuration
SM200252-BHX-XXX*	Bottom Mount Connector
SM200252-SHX-XXX*	Side Mount Connector

* XXX refers to custom configuration

Shipping Box Contents

SkyWave ships the terminal in an individual packaging box with the following parts:

- DMR-800D terminal - qty 1
- Installation Guide - qty 1 (this document)
- Mating connector * - qty 1
- Tube of silicone lubricant - qty 1

* Solution Provider may provide a cable instead of the mating connector.

Required Tools

Installation of the terminal requires the following tools:

- Drill and 5.5 mm drill bit
- Drill bit or 25 mm hole punch (bottom mount connector version only)
- Screwdriver
- Socket wrench set

Required Materials

Installing a terminal requires the following materials. These materials do not ship with the terminal since they differ for each installation.

- Qty 4 - M5 screws (length depends on mounting surface thickness)
- Qty 4 nuts with locking hardware
- Waterproof sealing tape
- Waterproof sealing compound such as RTV silicone (bottom connector version only)
- Custom cable

Terminal Cable

Although SkyWave ships the terminal with a mating connector, the Solution Provider may provide a terminal cable instead. Contact your Solution Provider if you did not receive a terminal cable, since the instructions for properly building this cable are beyond the scope of this guide.

The terminal accepts input ranges of 9 to 32 VDC. All cables should be less than 30m and be built with the following guidelines for minimum wire size based on voltage supplied to terminal.

Input Voltage	Minimum Wire Gauge	Recommended Fuse
9 to 32 VDC	20 AWG	2 Amp

For reliable operation, shield all cables used for power and data connections to the terminal.

SkyWave Mobile Communications Inc.
Phone: +1 613 836-6288 Press 1 for Customer Support

www.SkyWave.com

Installation Steps

CAUTION: It is typical to install the terminal on a mobile platform. In order to avoid hazards to person and property it is necessary for the installer to perform installations in a safe and secure manner. The installer is responsible for complying with local electrical codes.

Recording Serial Number

The terminal's serial number is located in three places: a label on the bottom of the terminal, a label on the original SkyWave packaging box and electronically inside the terminal. The serial number is the DCC010 number followed by six hexadecimal digits.

This number is a unique identifier for the terminal. Record this number before the terminal is mounted. You will need it later for commissioning the terminal on the satellite network.

Selection of Mounting Location

CAUTION: Mount the terminal at least 20cm (8 in) away from all persons.

- Fasten the terminal securely so that it is not loose and does not move easily.
- Mount the terminal on a solid, stable surface. If necessary, use a mounting bracket (not supplied) or other suitable support.
- Mount the terminal on a flat surface for mobile installations.
- Mount the terminal on a surface that is wide enough to support the base of the terminal. If necessary, use a mounting bracket (not supplied) or other suitable support.
- Mount away from heat sources. Mount the terminal on a surface that does not get hotter than the maximum operating temperature of 70°C. If the surface may get hotter, mount the terminal with a thermal barrier between it and the mounting surface.
- Mount the terminal where it has a clear view of the satellite. For a mobile installation, this means at the highest point on the vehicle or vessel where it has a clear view in all directions.
- Mount the terminal so that the Inmarsat satellite is within α degrees of the mounting surface where $\alpha = 0$ to 90 degrees. Make sure that the line of sight is clear of obstructions. Use the following guidelines:

Height of Obstruction	Min. Terminal Mounting Distance from Obstruction
0.5 m	5 m
0.4 m	4.5 m
0.3 m	3.5 m
0.2 m	2 m

- For fixed installations, the terminal can be 'pointed' at the satellite to improve performance. Contact SkyWave Customer Support for details.
- Do not mount the terminal too close to other electrical equipment (Electronic Magnetic interference) since it may interact because of radiated and conducted emissions.
- Do not drill any holes before checking that the terminal's cables comply with the bend radius specified by the supplier (Figure 1).

Figure 1 Cable Bend Radius

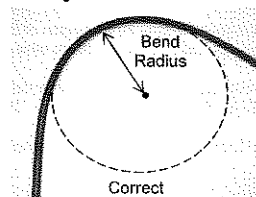

- Do not mount the terminal close to radar or other communications antennae. Use the following guidelines:
 - > 1 m from VHF/UHF antenna
 - > 3 m from loop antenna
 - > 4 m from MF/HF antenna
 - > 5 m from other satellite antennae and not within a radar beam

- Do not mount the terminal where water may build-up or collect.
- Do not block the drain holes in the slots on the bottom of the terminal.

Installation

Once you have selected the mounting location, mount the terminal. Select either bottom connector mounting (Figure 2) or the side connector mounting (Figure 3) depending on the mounting option.

In some cases, the Solution Provider may provide a mounting bracket with the terminal. In this case, the following instructions are not required. Refer to the instructions with the mounting bracket.

- Use the Drill template (see Figure 4) to mark the location of the four mounting holes and the connector hole.

The orientation of the terminal with a bottom connector is not important.

- Drill the four mounting holes using the drill with the 5.5 mm bit.
- Punch or drill the 25 mm hole for the connector (bottom connector mount only).
- Fill the ribbed channel around the connector and the space between the base plate and the terminal with waterproof sealing compound (bottom connector mount only).

Be careful not to block the drain holes in the slots on the bottom of the terminal (bottom connector mount only).

You can also apply waterproof sealing compound to the drilled mounting holes before inserting the screws.

- Secure the terminal in place with the mounting hardware using the screwdriver and socket set.
- Install the mating connector and cable using the silicon lubricant to protect the connector pins.
- Wrap the mating connector with waterproof sealing tape (if connector is exposed to elements).

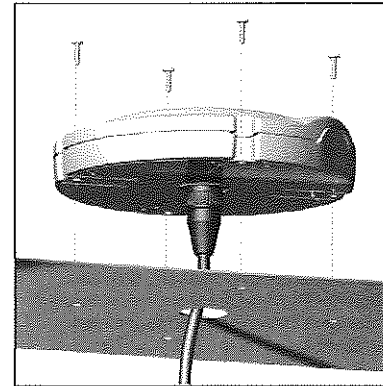

Figure 2
Bottom Connector DMR-800D
(SM200252-BXX-XXX)

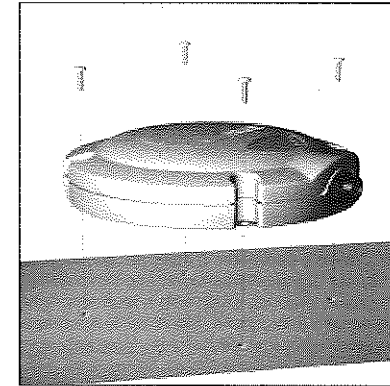

Figure 3
Side Connector DMR-800D
(SM200252-SXX-XXX)

Applying Power

Before connecting the terminal to an external voltage source, ensure that the polarity is correct and the voltage source is between 9 and 32 VDC. Refer to the connector pin-out description.

Connect the ground connection at the same time or before applying power. This is especially true when using the RS232 lines along with power and ground.

Verification

When the terminal is powered on, the ERR LED comes on for 5 seconds and the STAT LED flashes. This indicates that the terminal is correctly executing its startup self-test sequence. After about 5 seconds, the ERR LED will turn off and the STAT LED continues flashing at different rates. If the ERR LED remains on, the terminal is not functioning correctly.

Perform any additional verification procedures in cooperation with the Solution Provider as these vary depending on the installation and the Solution Provider's application.

Figure 4: Drill Template - DMR-800D Standard Bracket Mounting Plate

Plate Thickness 5.25 mm

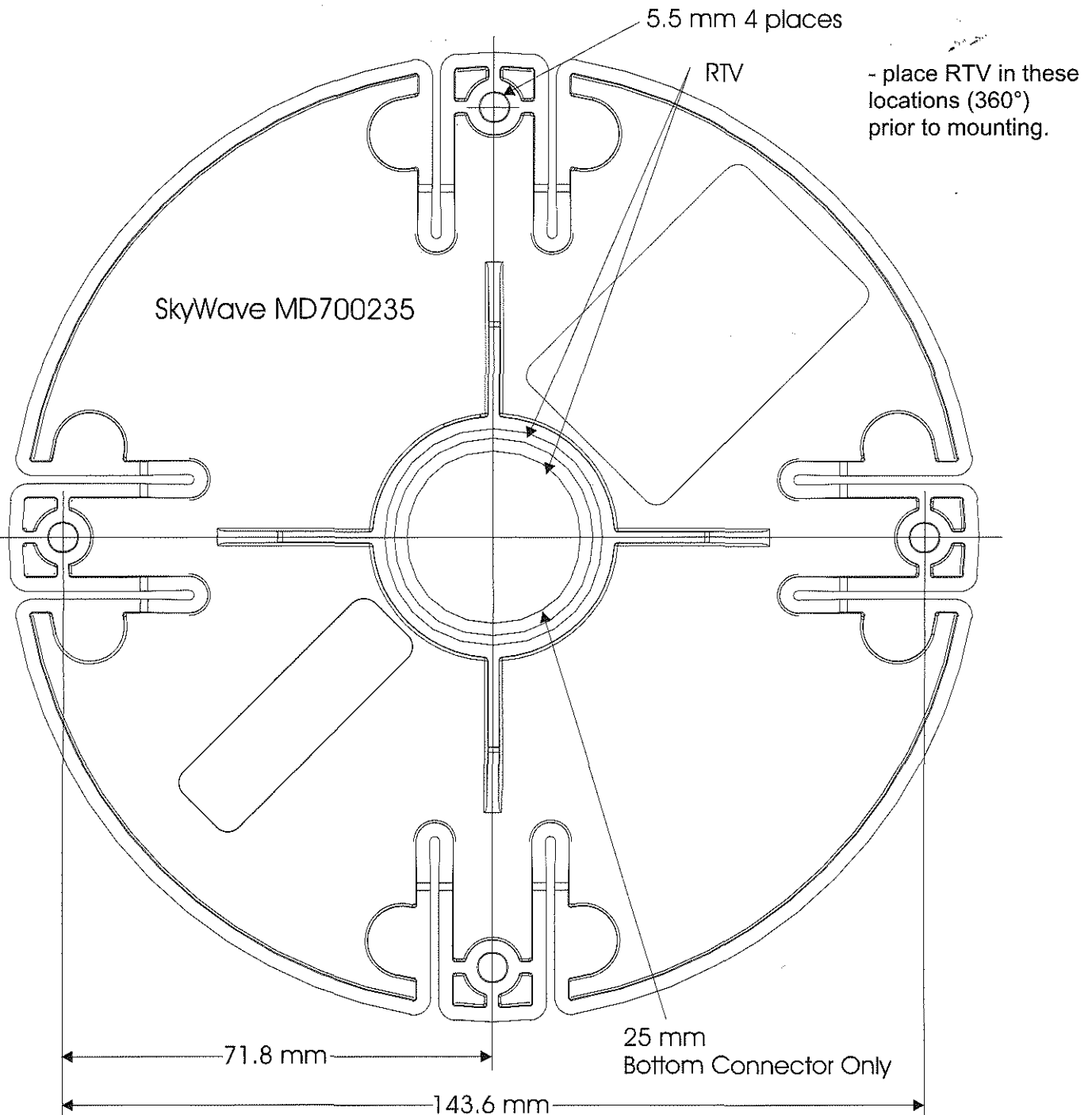

CAUTION: Before drilling check the template against actual hardware for dimensional accuracy. If it is not correct, DO NOT USE THIS TEMPLATE.